



Electrodiagnostic Medicine Consultation Physiology - Pathophysiology

Salekzamani Y .MD

Associate Professor

Department of Physical medicine and Rehabilitation

Tabriz Medical Sciences University



Cell body

- **Motor neuron**
- it is located in the anterior (ventral) horn region of the spinal cord and projects an axon distally.
- It regulates the characteristics of the entire motor unit.
- Cell bodies of **sensory neurons** are bipolar cells with two axons (one axon projects proximally and the other distally) and are found in the dorsal root ganglion (DRG), which is located outside the spinal cord in the proximity of the intervertebral foramen.

Axon

- This is the projection from the sensory or motor nerve cell body that propagates current flow and transports cell nutrition (axonal transport).
- It can be unmyelinated or myelinated by Schwann cells.
- At each spinal level, motor and sensory nerve roots combine to become a mixed spinal nerve.
- Each spinal nerve then branches off to a dorsal and ventral ramus.

Peripheral nerves

- Motor and sensory nerve fibers combine at various levels in the body (spinal nerve, ventral ramus, plexus) and ultimately terminate as peripheral nerves.

Motor/Sensory Nerves

- A peripheral **motor nerve** consists of multiple neural branches from the distal portion of the axon. They innervate individual muscle fibers.
- The amount of muscle fibers belonging to an axon is the innervation ratio (IR).
- This ratio varies, depending on the function of the motor unit.
- Muscles of gross movement have a larger amount of their fibers innervated by one axon (high ratio).
- Muscles of fine movement have a smaller amount of their fibers innervated by one axon (low ratio).
- The higher the IR, the greater the force generated by that motor unit.
- A myotome is a group of muscles that are innervated by one spinal segment.
- **Sensory nerves** innervate various segments in the body and are arranged into spinal segmental levels of innervation known as dermatomes.

Neuromuscular junction (NMJ)

- Motor nerves synapse with muscle fibers at sites known as NMJs.
- These sites are where the electric impulse propagated along the axon is converted into a chemical reaction.
- The signal is then translated back into an electrical impulse at the postsynaptic membrane to initiate muscle fiber action potentials.

Muscle fibers

- These extrafusal fibers are the final components of the motor unit
- Here, the electrical signal from the postsynaptic NMJ membrane stimulates muscle fiber depolarization and muscle fiber action potentials.
- Muscle fiber characteristics, including twitch response, depend upon the type of alpha motor neuron by which it is innervated.

Nerve Connective Tissue

- **Endoneurium** /surrounding each individual axon and its myelin sheath.
- **Perineurium** /This is the strong, protective, connective tissue surrounding bundles or fascicles of myelinated and unmyelinated nerve fibers.
 - It helps strengthen the nerve and acts as a diffusion barrier.
- **Epineurium** /
- This is the loose connective tissue surrounding the entire nerve that holds the fascicles together and protects it from compression.

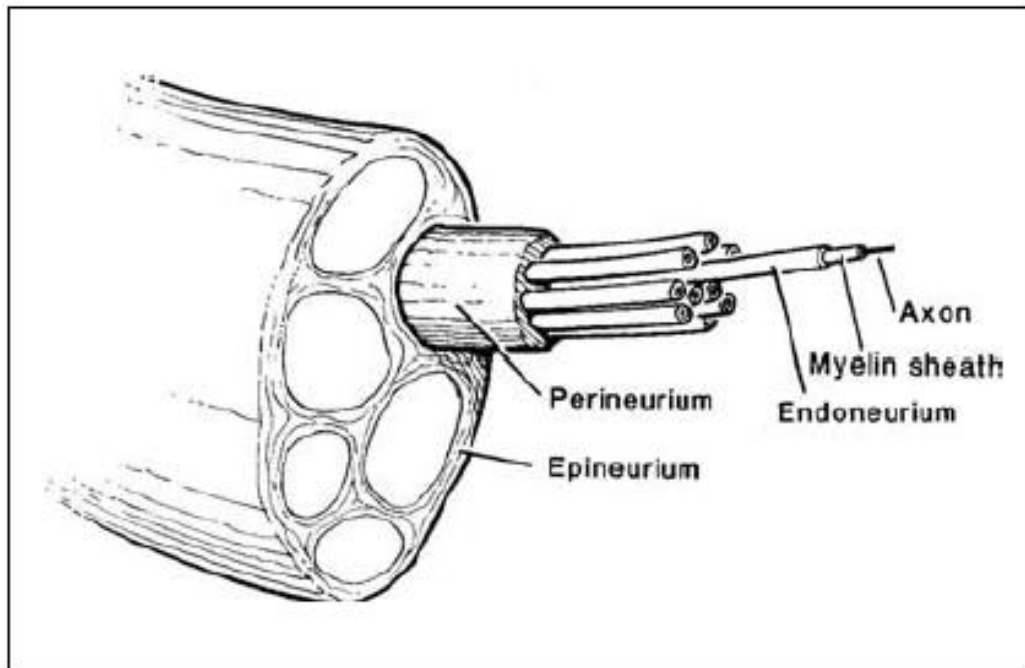

FIGURE 5-1 Neuronal connective tissue: The internal anatomy of the nerve. (From Buschbacher, 1994, with permission.)

The Motor Unit

- ☞ This motor unit is the basic functional element of the neuromuscular system.
- ☞ It consists of the following components:
 - ☞ — Anterior horn cell (motor nerve cell body)
 - ☞ — Motor nerve axons
 - ☞ — Peripheral nerve
 - ☞ — NMJ
 - ☞ — Muscle fibers

Motor Neurons

- The three motor neurons innervate specific fibers, extrafusal or intrafusal.
- Needle EMG is limited to evaluating the alpha motor neurons.
- The order of recruitment is related to their size, starting with the smaller motor units.
- This sequential activation allows for a smooth increase of contractile force and is described by the **Henneman Size Principle.**
- A smaller alpha motor neuron has a lower threshold of excitation, causing it to be recruited first during voluntary contraction.
- A larger alpha motor neuron has a higher threshold of excitation and is recruited when more motor units are needed to generate greater contractile force.

TABLE 5-1 Three Types of Motor Neurons

MOTOR NEURON	INNERVATIONS
Alpha	Extrafusal fibers—Skeletal muscle
Gamma	Intrafusal fibers—Muscle spindle
Beta	Intrafusal and extrafusal fibers

MUSCLE FIBER TYPES

FIBER TYPE	INNERVATION CHARACTERISTICS
Type I	Smaller cell body
	Thinner diameter axon
	Lower innervation ratio
	Slower twitch muscle fibers
Type II	Larger cell body
	Thicker diameter axon
	Higher innervation ratio
	Faster twitch muscle fibers

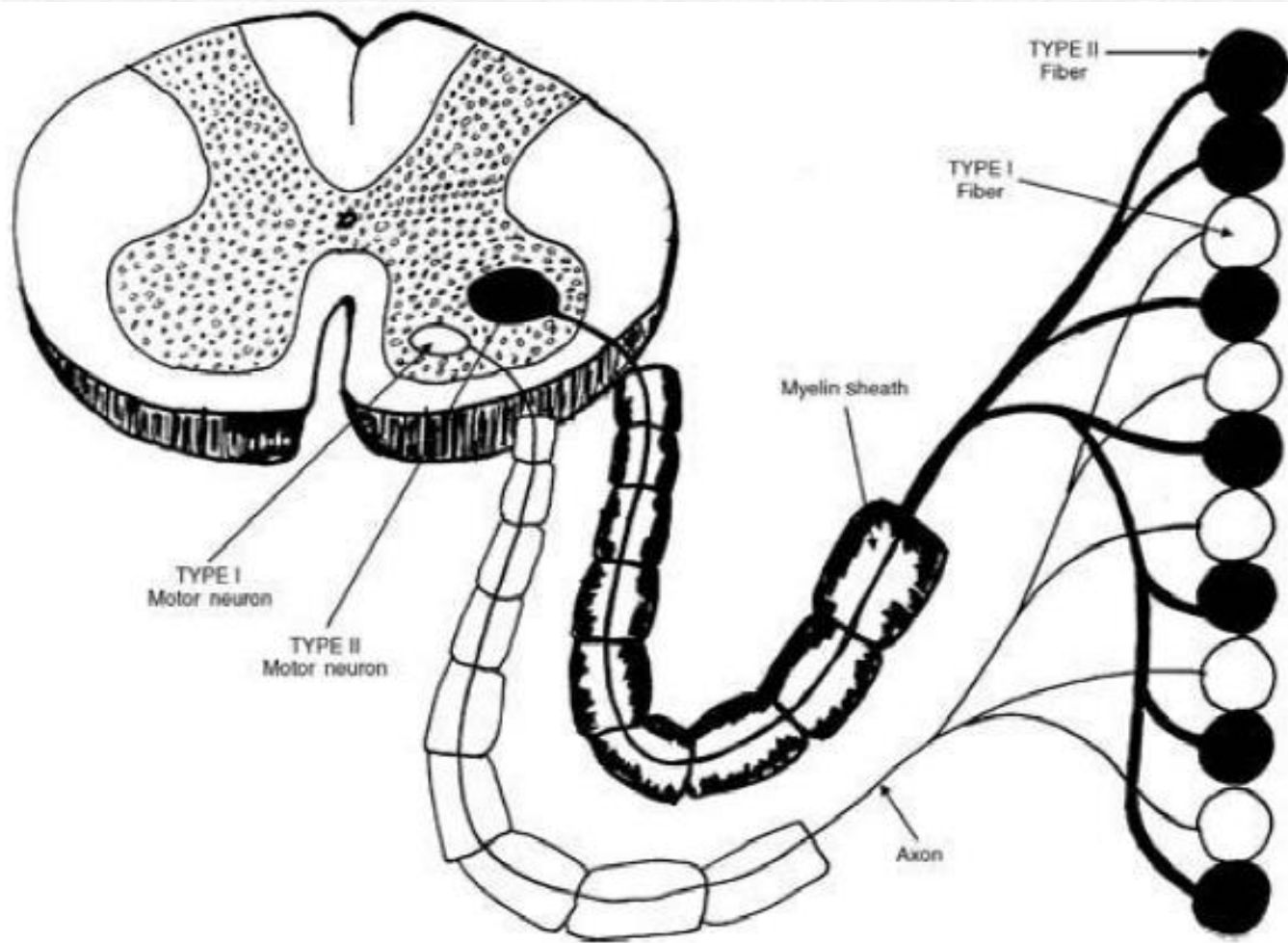

Description of Type I and Type II alpha motor neurons.

Nerve Fiber Classification

LLOYD AND HUNT (SENSORY)	ERLANGER AND GASSER (SENSORY AND MOTOR)	DIAMETER (μm)	VELOCITY (m/sec)	FUNCTION
Ia fibers	A-alpha fibers	10 to 20 largest	50 to 120 fastest	Motor: Alpha motor neurons Sensory: muscle spindle
Ib fibers	A-alpha fibers	10 to 20	50 to 120	Sensory: Golgi tendon organ, touch, pressure
II fibers	A-beta fibers	4 to 12	25 to 70	Motor: Intrafusal and extrafusal muscle fibers Sensory: Muscle spindle, touch, pressure
III fibers	A-gamma fibers A-delta fibers	2 to 8 1 to 5	10 to 50 3 to 30	Motor: Gamma motor neurons, muscle spindle Sensory: Touch, pain, temperature
IV fibers	B-fibers C-fibers	1 to 3 <1	3 to 15 <2	Motor: Postganglionic autonomic fibers Motor: Preganglionic autonomic fibers Sensory: Pain, temperature

Resting Membrane Potential (RMP)

- This is the voltage of the axon's cell membrane at rest. Normal RMP is -70 to -90 mV.
- *Leak channels*
- These are openings in the cell membrane that allow sodium (Na^+) and potassium (K^+) to move passively in and out of the cell membrane.
- *Na^+-K^+ ATP-dependent pumps*
- A negative potential is maintained inside the cell by actively exporting three Na^+ ions while importing two K^+ ions through Na^+-K^+ ATP-dependent pumps located within the cell's semipermeable membrane.

Depolarization

- When an outside current is applied to a nerve by a stimulator consisting of a cathode (negative pole) and an anode (positive pole), positive charges on the axon become attracted under the cathode and lower the membrane potential.
- The membrane becomes increasingly permeable to Na^+ , which rushes into the cell through the opened voltage-gated channels toward an equilibrium. This process of sodium conductance is the most important event in generating an action potential.
- **Action potential**
- This is a voltage change occurring from an excited cell. The electric impulse propagates along an axon or muscle membrane.
- The all-or-none response travels in both directions along the axon.

Propagation

- As Na^+ goes into the cell from a depolarization, it moves away from the membrane and spreads the current down a path of least resistance along the length of the axon
- The affinity to flow back out through the membrane is low due to the myelin sheath covering. Thus, the potential “jumps” to the next group of Na^+ channels, located between the myelin, to areas called the nodes of Ranvier.
- This process of propagating a current from one node to another is known as saltatory conduction.

Neuromuscular Junction (NMJ)

- The distal portion of a motor axon has small twig-like terminal branches that innervate individual muscle fibers.
- This portion of the nerve and single muscle fiber forms the motor endplate.
- The axon terminal, containing various neural structures, including mitochondria and synaptic vesicles with acetylcholine (ACh), does not make direct contact with the muscle fiber.
- Rather, it remains separate from it by primary and secondary synaptic clefts

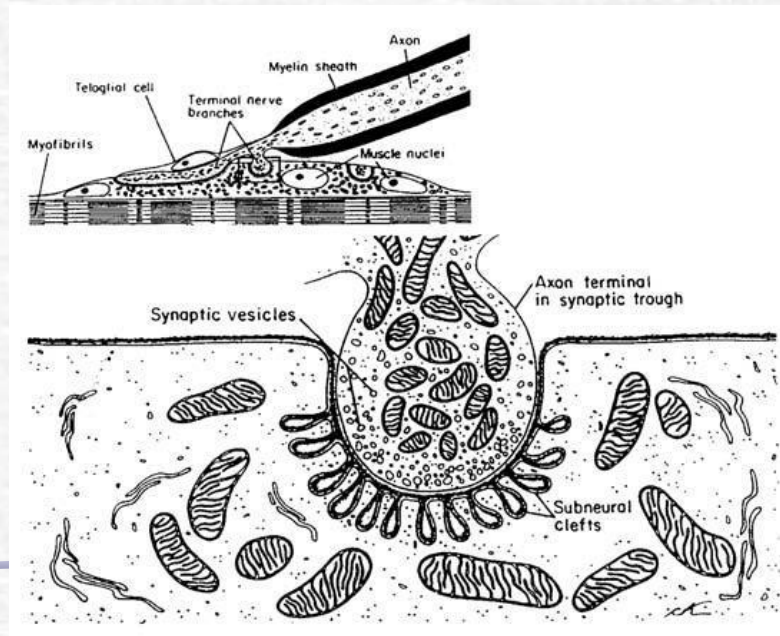

Presynaptic region

- This bulbous area at the axon's terminal zone is comprised of three storage compartments containing ACh.
- They are contained in packets called quanta consisting of approximately 5,000 to 10,000 molecules.
- The ACh migrates from the main and mobilization storage compartments to replenish the immediate storage compartment, which is depleted in the process of generating each action potential.
- This migration of ACh takes approximately 4 to 5 seconds.

STORAGE COMPARTMENTS	CONTENT
Main store	300,000 quanta
Mobilized store	10,000 quanta
Immediate store	1,000 quanta

Synaptic cleft

- This is a space 200 to 500 angstroms wide where ACh crosses from the presynaptic region toward receptors on the postsynaptic region.
- It contains an enzyme called acetylcholinesterase, which degrades ACh into acetate and choline as it crosses the cleft.

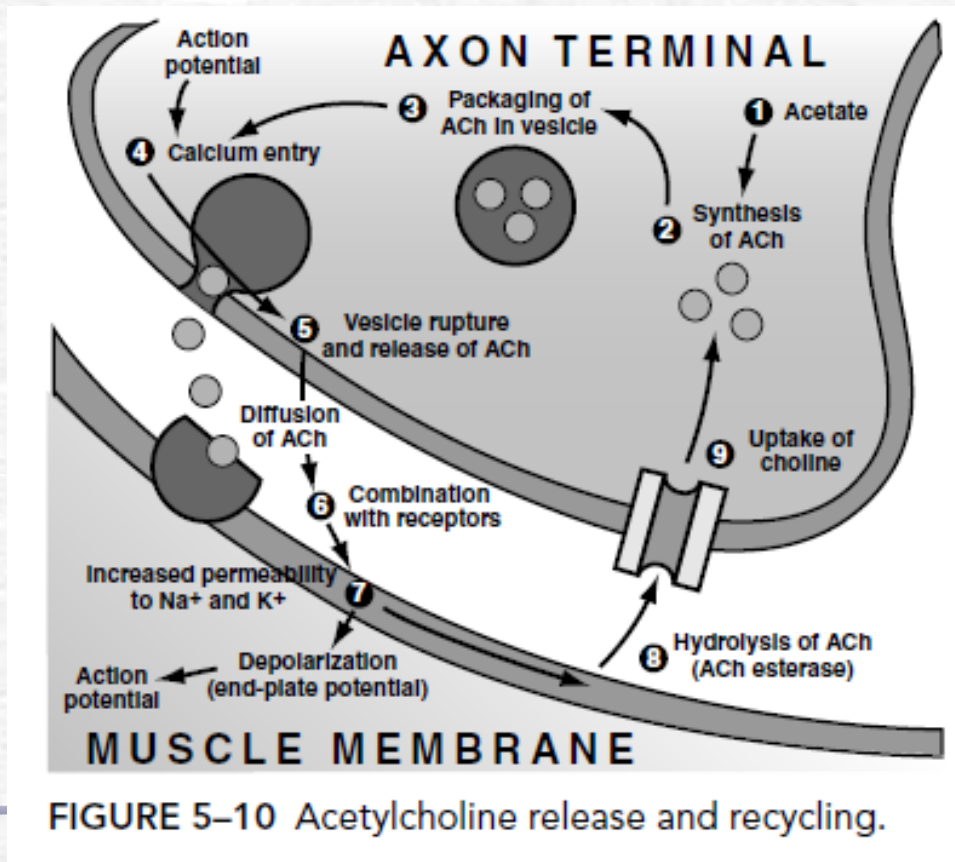

Postsynaptic region

- This is a membrane lined with ACh receptors.
- It has convolutions to increase its surface area by approximately 10x the surface of the presynaptic membrane.
- At the crests of each fold, receptors are located across from the presynaptic active zones, which are the sites of ACh release.
- Each postsynaptic ACh receptor requires two molecules of ACh to become activated.

NMJ Physiology

- ✓ Resting state
- ✓ Excited state
- ✓ Safety factor

Resting state

- During the periods of inactivation, a spontaneous release of a quanta occurs every 5 seconds.
- This results in production of one miniature endplate potential (MEPP).

Excited state

- During the periods of activation, a nerve depolarization opens voltage-gated calcium (Ca^{++}) channels.
- Ca^{++} floods the nerve terminals and remains there approximately 200 ms.
- This leads to the release of multiple quanta into the synaptic cleft, which increases the amount of MEPPs.
- These MEPPs summate to form an endplate potential (EPP), which generates a motor unit action potential (MUAP)

Safety factor

- The amplitude of an EPP must be high enough to initiate an action potential.
- Normally, the EPP's amplitude is four times the amount needed to initiate an action potential.
- However, the EPP's amplitude drops each time the EPP is created due to a drop in immediate available ACh.
- This initial excess amplitude of the EPP is called the *safety factor* and allows time for ACh to move from the main and mobilizing storage compartments to replenish the immediate storage compartment.
- This avoids a drop of the EPP's amplitude below the threshold needed to cause an action potential.
- **The safety factor depends on two parameters:**
- Quantal content: Number of ACh quanta released with each nerve depolarization.
- Quantal response: Ability of the ACh receptors to respond to the ACh molecules that are released.

Skeletal Muscle Fiber

- A cylindrical, multinucleated cell containing contractile elements composed of actin and myosin.
- The sarcomere is a basic unit of a muscle's myofibril.
- A sarcomere runs from Z-line to Z-line. Its size changes during contraction

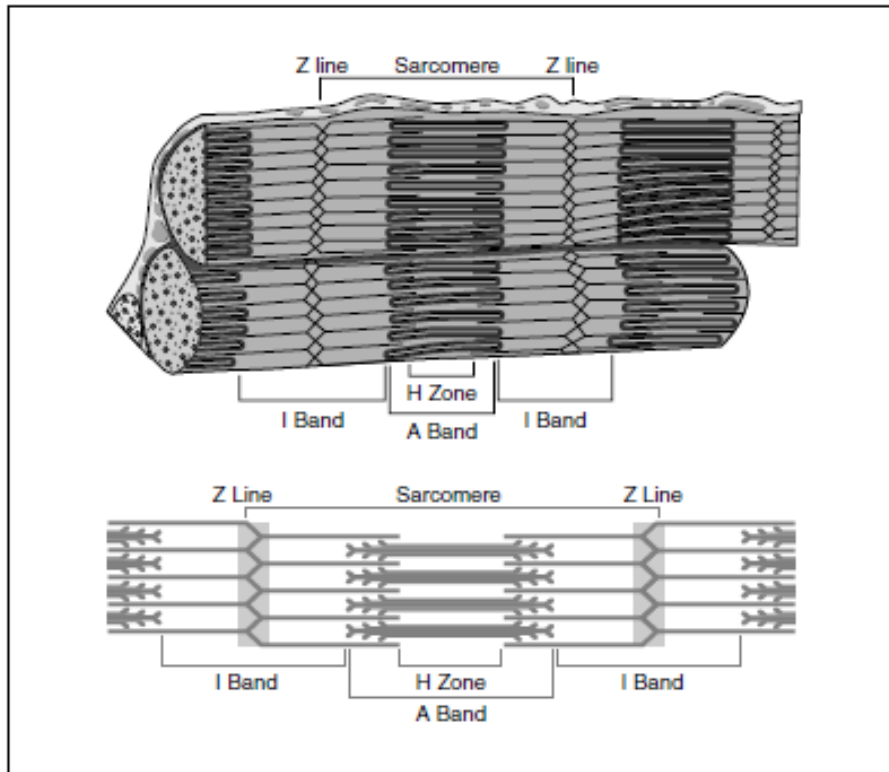

FIGURE 5-11 The sarcomere.

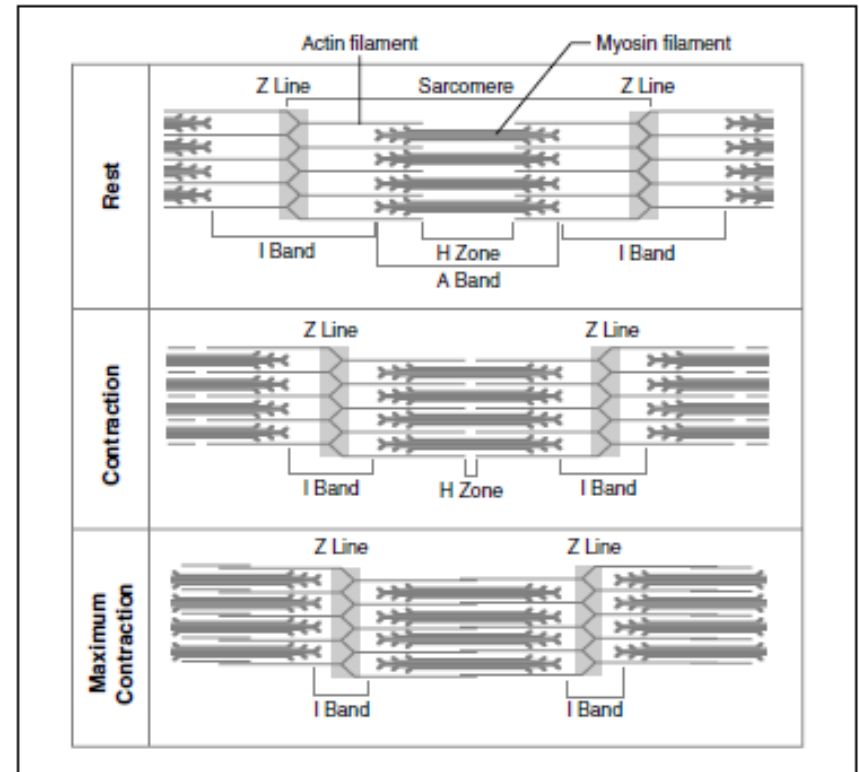

FIGURE 5-12 Sarcomere positional changes.

Muscle Fiber Classification

Muscle Fiber Classification

CHARACTERISTICS	TYPE I (SO) SLOW TWITCH OXIDATIVE	TYPE II-A (FOG) FAST TWITCH OXIDATIVE-GLYCOLYTIC	TYPE II-B (FG) FAST TWITCH GLYCOLYTIC
Alpha motor neuron	Small	Large	Large
Color	Dark	Dark	Pale
Recruitment	Early	Late	Late
Fatigue	Highly resistant	Resistant	Sensitive
Effort	Mild (4 to 8 Hz)	Intermediate (20 to 30 Hz)	High (20 to 30 Hz)
Firing frequency	Slow, prolonged	Fast, unsustained	Fast, unsustained
Movements	Fine, precise	Gross	Gross
Innervation ratio	Small	Large	Large
Amplitude/duration	Small	Large	Large
O ₂ capacity	Aerobic	Anaerobic	Anaerobic



Pathophysiology



Demyelination

- An injury to the myelin sheath of the nerve, but the axon remains intact.
- Demyelination increases the membrane capacitance due to the loss of myelin insulation, thus hindering saltatory conduction.
- Slower signal conduction along the axon.
- The trophic factors of the nerve are maintained
- Myelin regeneration is possible due to Schwann cell proliferation
- Acutely, conduction block can occur.
- With time, remyelination can occur.
- In some chronic disease states, demyelination and remyelination occur repeatedly.

Conduction Block

- Failure of an AP to propagate past an area of demyelination along axons that are otherwise structurally intact
- It can present as a greater than 50% drop in CMAP amplitude between proximal and distal stimulation sites across the area of injury.

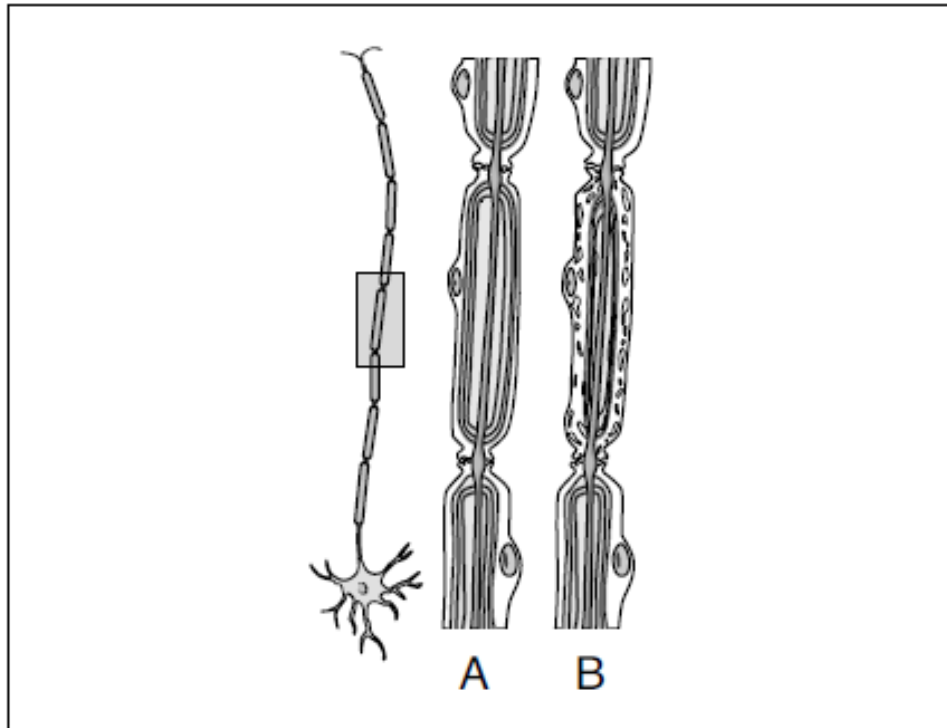

Demyelination. (A) Normal nerve.
(B) Injured segment with myelin breakdown.

Etiology

- Compression causing a transient ischemic episode, edema, or myelin invaginations with paranodal intussusceptions
- Diseases causing degradation of myelin leading to peripheral neuropathies.

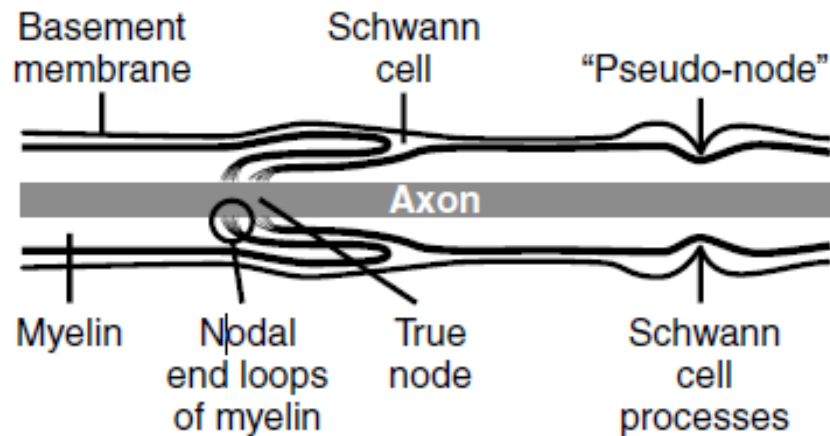

Paranodal intussusception. Diagram of an invaginating paranode into an adjacent one.

Demyelination/ EDX findings

- Electrodiagnostic findings of demyelination

NCS	EMG
Latency: Prolonged Conduction velocity: Decreased Temporal dispersion: Increased Amplitude: Decreased across site of injury	Normal insertional activity Resting activity: Normal, \pm myokymia Recruitment: Normal or decreased MUAP: Normal

Recovery in Demyelination

- ✓ **Self-limited**
- ✓ The pathology can reverse with cessation of the insulting event.
- ✓ Transient ischemia can be immediately reversed, but edema can take several weeks.
- ✓ **Remyelination**
- ✓ This is a process of repair in which the demyelinated region develops new myelin produced by the Schwann cells.
- ✓ This new myelin is thinner with shorter internodal distances.
- ✓ CV improves but is usually slower than normal.

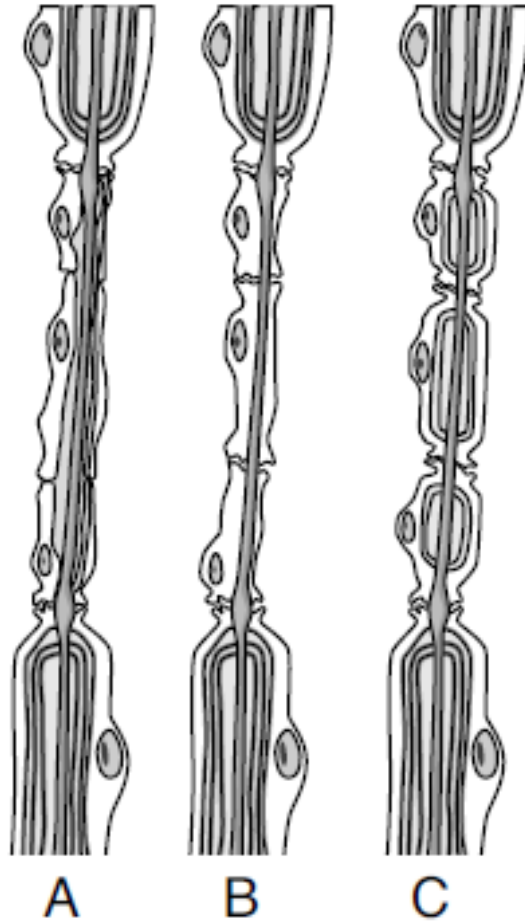

Remyelination. (A) Myelin digestion and Schwann cell proliferation. (B) Myelin is removed. (C) Remyelination is complete.

Axonal Injury

- ☞ two typical forms:
- ☞ **Axonal degeneration**
- ☞ A nerve injury that begins in a “dying back” fashion and affects the nerve in a length-dependent manner.
- ☞ Degeneration of the axon starts distally and ascends proximally.
- ☞ **Wallerian degeneration.**
- ☞ At the site of a nerve lesion, the axon degenerates distally. The nerve segment proximal to the injury site is essentially intact with some minor dying back at the lesion site 1 to 2 cm.
- ☞ For the distal motor axons, the degeneration is generally complete in 7 days.
- ☞ For the distal sensory axons, the degeneration is generally complete in 11 days.

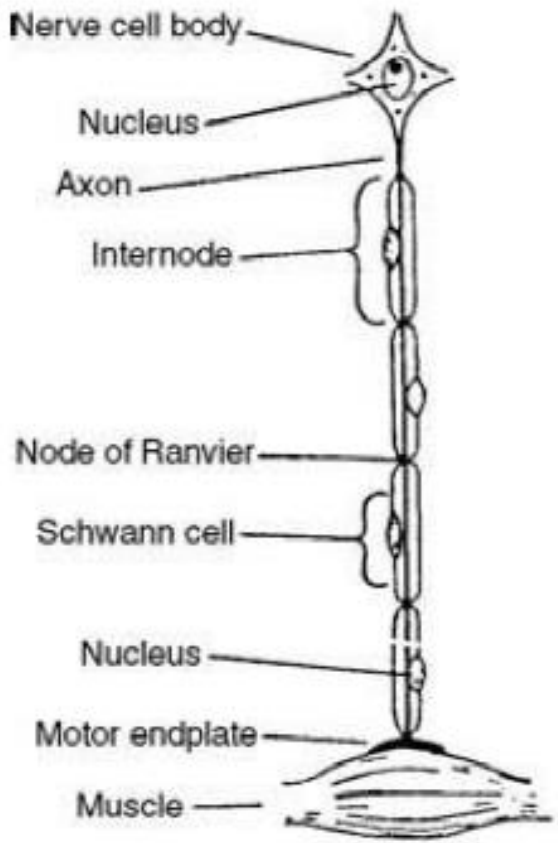

Normal

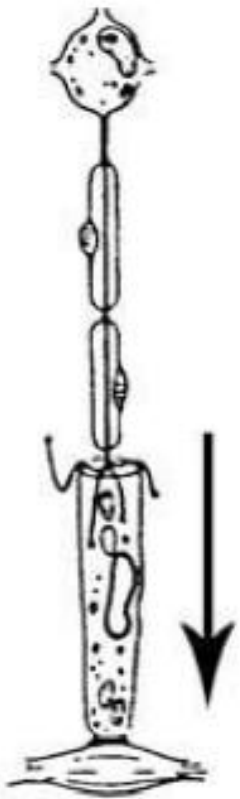

Wallerian degeneration

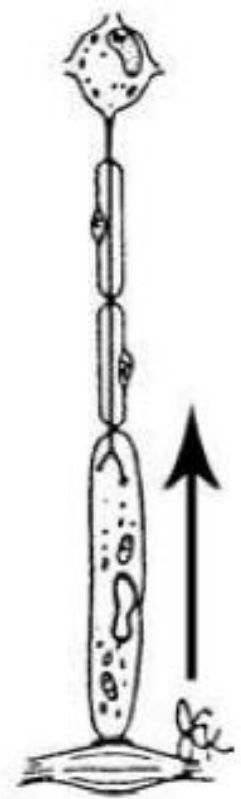

Axonal degeneration

Etiology of Axonal Injury

- ✓ Focal crush
- ✓ Stretch
- ✓ Transection
- ✓ Peripheral neuropathies

Axonal Injury / EDX findings

NCS	EMG
Latency: Normal Amplitude: Decreased Temporal dispersion: Normal Conduction velocity: Mildly decreased	Insertional activity: Abnormal Resting activity: Abnormal Recruitment: Decreased MUAP: Abnormal

Recovery in Axonal Injury

- Collateral sprouting
- Axonal regrowth

Collateral sprouting

- This is a process of repair in which a neurite sprouts off the axon of an intact motor unit and innervates denervated muscle fibers of an injured motor unit.
- The sprouts connect with smaller terminal branches, thinner myelin, and weaker NMJs.
- Increased fiber type grouping occurs as muscle fibers become part of the new motor unit and take on its characteristics, increasing the size of its territory.
- This remodeling results in motor units with poor firing synchronicity, secondary to the immature terminal sprouts.
- This results in polyphasic waveforms with increased amplitudes.





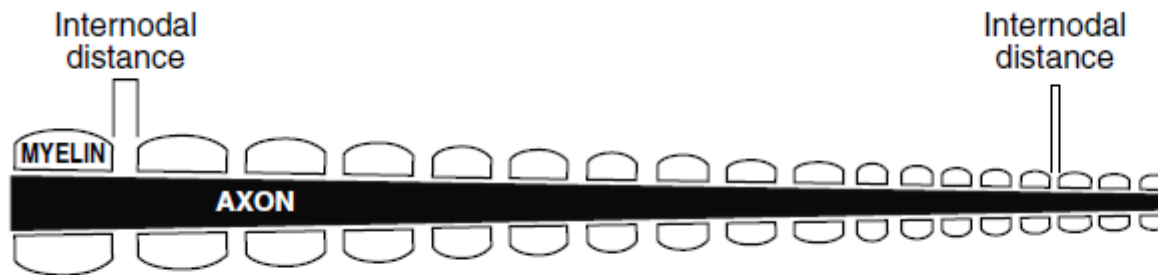





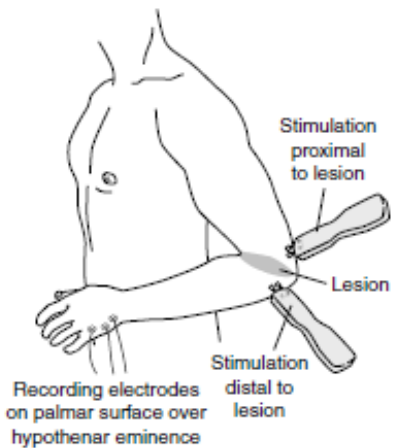







Axonal regrowth

- This is a process of repair in which the axon will regrow down its original pathway toward its muscle fibers.
- It will travel approximately 1 mm per day or 1 inch per month (35 mm per month) if the supporting connective tissue remains intact.
- These axons will have a decreased diameter, thinner myelin, and shorter internodal distance.
- With reinnervation, low amplitude, long duration, and polyphasic potentials known as nascent potentials are formed.
- If the connective tissue is not intact to guide proper nerve regrowth, a neuroma can form with failure to reach the final end organ.
- Concomitantly, the shorter the distance from injury to end organ, the higher the likelihood for a better prognosis.



Axonal regrowth: Axonal diameter is decreased. Myelin is thinner. Internodal distance is shorter.

Seddon Classification

CHARACTERISTICS	NEUROPRAXIA		AXONOTMESIS		NEUROTMESIS		
Etiology	Nerve compression injury		Nerve crush injury		Nerve transection injury		
Description	Axon is intact Local myelin injury Conduction block		Axonal interruption Connective tissue/ Schwann cell intact Conduction failure		Axonal interruption Connective tissue disruption Conduction failure		
Nerve conduction studies	The signal is normal distal to the lesion and abnormal across it		Conduction resembles neuropraxia for 4–5 days, until Wallerian degeneration occurs		Conduction initially resembles axonotmesis but does not demonstrate recovery		
 <p>Stimulation proximal to lesion</p> <p>Lesion</p> <p>Stimulation distal to lesion</p> <p>Recording electrodes on palmar surface over hypothenar eminence</p>	Waveform distal to lesion: Immediate  2 weeks  >2 weeks 	Waveform proximal to lesion:   	Waveform distal to lesion: Immediate  2 weeks  weeks–months 	Waveform proximal to lesion:   	Waveform distal to lesion: Immediate  2 weeks  2 years 	Waveform proximal to lesion:   	
	EMG	Normal/decreased recruitment		Abnormal activity		Abnormal activity	

Sunderland Classification

TYPE 1	Conduction block (neuropraxia)
TYPE 2	Axonal injury (axonotmesis)
TYPE 3	Type 2 + Endoneurium injury
TYPE 4	Type 3 + Perineurium injury
TYPE 5	Type 4 + Epineurium injury (neurotmesis)

